



TITAN[®]

HIGH PERFORMANCE PROTECTIVE COATINGS



SCAN FOR
DIGITAL COPY



SPRAYING **REDEFINED**



HYDRA X™ SERIES

The Hydra X Series delivers when jobs call for the toughest coatings. The Direct Immersion System eliminates the need for transfer pumps, flexible siphon tubes, and air compressors, maximizing efficiency. The AutoLift™ system raises and lowers the fluid section with the push of a button so contractors can spend less time setting up and more time spraying.



Hydra X Features:



Smart Design

- Effortless drum changes with the electric **AutoLift™** system that raises and lowers the fluid section with the touch of a button
- One sprayer with modular fluid sections allowing for two different performances out of one sprayer
- Large 12" pneumatic tires make it easy to move around job site

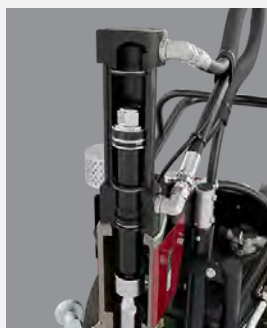

HydraStroke® Technology

- Unmatched durability and performance powered by electronically controlled hydraulics
- Versatility to spray heavy and light bodied coatings without burning the clutch
- Hydraulic motor is optimized with one moving part, reducing heat and extending life

Severe Service™ Fluid Section

- 5" long, ultra slow stroking piston maximizes power and efficiency to extend the pump life
- Uses a Tri-chrome process to create the industry's most durable fluid section with packings designed specifically for aggressive coatings
- Titan self-adjusting packings extend the time between maintenance
- Proven Titan technology with over 45 years in the field
- **Patent-pending quick removal fluid section** allows one person to service or convert on the jobsite with ease

Extremely Efficient Cooling System

- Two cooling fans to maximize air flow over hydraulic system
- Large 6 gallon hydraulic fluid reservoir

Powered by

HONDA®

- Fuel efficient, High output operation
- Exceptionally quiet
- Proven reliability
- Easy starting

Hydra X 4540

Powerhouse hydraulic sprayers recommended for very large scale residential, commercial, corrosion control and industrial projects where up to 6 guns are needed.



Hydra X 7230

Powerful high pressure sprayer for hard to atomize materials like silicone and epoxies.

	Hydra X 4540	Hydra X 7230
SPECIFICATIONS		
Max. Delivery	4.0 gpm	3.0 gpm
Max. Tip Size	0.067"	0.057"
Max. Operating Pressure	4500 psi	7200 psi
Volumetric Flow per Double Stroke	247 cm ³ /DS	162 cm ³ /DS
Engine	390cc Honda® GX390	390cc Honda® GX390
CONFIGURATIONS		
Part No 49 States	2412275	2412277
Part No California	2412275X	2412277X
Part No Kohler Engine	2412275K	2412277K
Part No 49 States 250' GHT	2424560	2424561
Part No California 250' GHT	2424560X	2424561X
Part No Kohler 250' GHT	2424560K	2424561K

POWRTWIN™ & POWRBEAST® SERIES

Hydraulic piston sprayers have been the choice for serious contractors for large scale residential, commercial, corrosion control and industrial applications.



■ PowrTwin 12000 Plus

PowrTwin 12000 Plus DI ■

PowrTwin™ 12000 Plus | 12000 Plus DI

A powerhouse convertible hydraulic sprayer recommended for very large scale residential, commercial, corrosion control and industrial projects where up to 6 guns are needed.

PowrTwin 12000 Plus comes complete with RX-Apex Non-filtered Gun, 517 TR¹ Reversible Tip and 1/4" x 50' Airless Hose. PowrTwin 12000 Plus DI comes complete with RX-Apex Non-filtered Gun, 517 TR¹ Reversible Tip and 3/8" x 50' Airless Hose.

	PowrTwin 12000 Plus	PowrTwin 12000 Plus DI
SPECIFICATIONS		
Max. Delivery - Gas	3.15 gpm	3.15 gpm
Max. Delivery - Electric	1.25 gpm	1.25 gpm
Max. Tip Size (1-Gun) - Gas	0.058"	0.058"
Max. Tip Size (2-Guns) - Gas	0.040"	0.040"
Max. Tip Size (1-Gun) - Electric	0.036"	0.036"
Max. Tip Size (2-Guns) - Electric	0.026"	0.026"
Max. Operating Pressure	3600 psi	3600 psi
Engine	270cc Honda [®] GX 270	270cc Honda GX 270
CONFIGURATIONS		
	PART NO.	PART NO.
With Gas Engine	290016	290023
ConvertoKit	0290311A	0290311A



PowrBeast® 9700

Built with powerful HydraStroke™ Technology, Severe Service Fluid Section and a smart design that makes jobsite life easier the PowrBeast can tackle large residential, commercial and industrial projects with ease.

Comes complete with RX-Pro Gun, 517 TR¹ Reversible Tip and 1/4" x 50' Airless Hose.

	PowrBeast 9700
SPECIFICATIONS	
Max. Delivery	3.00 gpm
Max. Tip Size (1 Gun)	0.055"
Max. Tip Size (2 Guns)	0.039"
Max. Tip Size (3 Guns)	0.031"
Max. Tip Size (4 Guns)	0.027"
Max. Tip Size (5 Guns)	0.023"
Max. Operating Pressure	3300 psi
Engine	270cc Honda GX 270
CONFIGURATIONS	
	PART NO.
PowrBeast 9700 Gas	537007

POWRCOAT™ SERIES

The durability, reliability, and ease of operation that you need are built in to each unit. Severe Service™ means twice the life with half the maintenance. PowrCoat Sprayers have been used throughout the world, providing their owners with dependable, efficient operation.



Severe Service Fluid Section

Features self-adjusting packings.

Severe Service Piston Rod and Cylinder

Titan's proprietary hard-chrome plating is the hardest and slickest wear surface in the industry.

High Capacity Outlet Filter

Featuring 3 outlet ports, manual pressure relief/recirculation valve and easy-on/off filter element access.

Air Filter, Moisture Separator, Regulator and Lubricator

Included on all PowrCoat models.

Heavy-Duty Frame

Features large 16" pneumatic tires, convenient lift handles, heavy-duty crane hook and high capacity hose rack that holds up to 200 feet of 1/2" hose.

Severe Service™ Pump is Standard

A PowrCoat Piston

Engineered to provide unmatched chemical and solvent resistance while creating an ultra-smooth surface, providing less friction and wear.

B Tungsten Carbide Valve Seats

Provides maximum life and smooth, efficient operation with hardened stainless steel check balls.

*Alternate packing materials are available for specialized applications.

Easily Cleaned or Replaced Full-Size Filter

Stainless Steel Ball Check Valve

Self-Adjusting, Spring-Loaded Packings*

Severe Service™, Hard Chrome Piston and Cylinder

Adjustable Ball Guide
(Models 730, 940, 1045, 1064 and 1072)

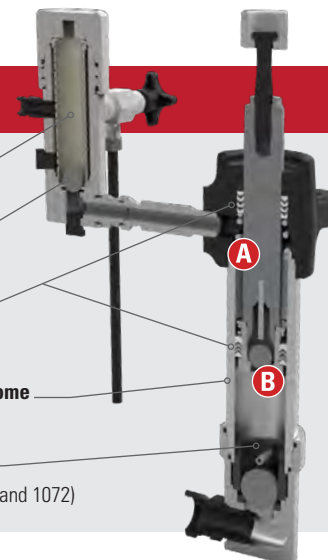

A SPRAYER FOR EVERY APPLICATION



PowrCoat Technical Data

	730	745	940	960	1045	1064	1072
SPECIFICATIONS							
Air Motor Diameter (inches)	7	7	9	9	10	10	10
Ratio	30:1	45:1	40:1	60:1	45:1	64:1	72:1
Stroke Length (inches)	4.0	4.0	4.0	4.0	4.75	4.75	4.75
Max. Operating Pressure (psi)	3000	4500	4000	6000	4500	6400	7250
Max. Air Input Pressure (psi)	100	100	100	100	100	100	100
Volume Flow - 60 CPM	3 gal (10.7 l)/min	2 gal (7.3 l)/min	3 gal (10.7 l)/min	2 gal (7.3 l)/min	4 gal (15.2 l)/min	3 gal (11.3 l)/min	3 gal (10.0 l)/min
Approximate Air Requirement Per Gallon of Output @ 100 psi (6.9 bar) Air Pressure	28.0 SCFM (0.79 m ³ /min)	40.0 SCFM (0.79 m ³ /min)	36.4 SCFM (1.03 m ³ /min)	53.0 SCFM (1.50 m ³ /min)	43.0 SCFM (1.22 m ³ /min)	57.7 SCFM (1.63 m ³ /min)	64.9 SCFM (1.84 m ³ /min)
Max. Recommended Air Volume Requirements (CFM)	112	148	145	148	172	174	175
Fluid Output Per Cycle (cc)	182	114	182	114	254	188	167
Max Tip @ 60 cpm	0.057	0.037	0.057	0.041	0.045	0.053	0.057
Cart Part Number	0533730C	0533745C	0533940C	0533960C	05331045C	05331064C	05331072C
55-Gallon Material Suction Feed Assembly Kit (Optional)	103-808 (1")	103-808 (1")	103-808 (1")	103-808 (1")	0533259 (1")	0533259 (1")	0533259 (1")

Optional Liquids: Air Care 1qt (311-101), Piston Lube 1qt (700-926), Solvent Piston Lube (91-36)

RX-APEX™

AIRLESS SPRAY GUN



RX-Apex ▶
Non-filtered
Version

- 2X
LIFE **Infinity Packing®**
2X the gun life by reversing the seat and changing the ball.
- Fingerprint **FingerPrint+ Grip™**
Fully adjustable grip delivers maximum customization.
- 24 **All-Day Trigger**
28% lighter trigger pull force and 74% less hold force.
- Free-Flow Swivel **Free-Flow Swivel**
Only direct-feed airless gun with built-in swivel.

- ▶ Filtered and non-filtered versions
- ▶ Pressure rated at 5000 psi (34.5 MPa)

DESCRIPTION	PART NO.
Filtered Gun with TR ¹ Tip	0538075
Non-Filtered Gun with TR ¹ Tip	0538070

S-7 Airless Gun

- ▶ In-handle filter
- ▶ Available in two swivel sizes
- ▶ Easy 4-finger trigger pull
- ▶ Swivel reduces hose kinks
- ▶ Includes 517 TR¹ high pressure, heavy-duty reversible tip and guard
- ▶ Pressure rated at 7700 psi (53.1 MPa)



DESCRIPTION	PART NO.
S-7 Gun with 1/4" Swivel	550-260
S-7 Gun with 3/8" Swivel	550-270
S-7 Repair Kit	550-276

RX-PRO®

AIRLESS SPRAY GUN



- Infinity Packing **Infinity Packing®**
2X the gun life by reversing the seat and changing the ball.
- Fingerprint **FingerPrint Grip®**
Customize the grip to comfortably fit any painters hand.
- 2X
LIFE **Ultra-Light Trigger**
30% lighter than the competitors trigger pull decreasing fatigue.
- Onboard Tools **Onboard Tools**
Smart tools that make jobsite life easier.

- ▶ Comes with both 2 and 4-finger trigger
- ▶ Pressure rated at 3600 psi (24.8 MPa)

DESCRIPTION	PART NO.
RX-Pro Airless Gun with TR ¹ Tip	0538020
RX-Pro Gun, Hose and Tip Kit*	0538022
RX-Pro Ball Valve	0538221
RX-Pro Seat	594-033
RX-Pro Packing Seal Assy.	0538204A

*Includes additional a 3' whip hose.

M-4 and M-8 Mastic Guns

- ▶ Straight line fluid passage allows max flow rate
- ▶ Angled handle for increased comfort
- ▶ Adjustable needle packing prolongs the life of critical wear parts
- ▶ Swivel allows freedom of movement without hose kinking
- ▶ Lightweight metal construction

DESCRIPTION	psi	PART NO.
M-4 Mastic Gun w/ 3/8" Swivel	3600 (24.8 MPa)	0289013
M-8 Mastic Gun w/ 3/8" Swivel	7700 (53.1 MPa)	2425442
M-8 Mastic Gun w/ 1/4" Swivel	7700 (53.1 MPa)	0289014
M-4 / M-8 Repair Kit	---	2347489

RX-80™

AIRLESS SPRAY GUN



- Hand **Comfort Grip™**
Ergonomic design brings added comfort.
- Clock **Longer Life Packing Kit**
Lasts longer with improved performance.
- Wrench **Onboard Tools**
Smart tools that make jobsite life easier.

- ▶ Comes with 2 or 4-finger trigger
- ▶ Pressure rated at 3600 psi (24.8 MPa)

DESCRIPTION	PART NO.
RX-80, 4-Finger with TR ¹	0538005
RX-80, 2-Finger with TR ¹	0538006
RX-80, 4-Finger with SC-6+	0538007
RX-80, 2-Finger with SC-6+	0538008
RX-80, 4-Finger, Hose and Tip Kit w/ TR ¹ *	0538010
RX-80, 4-Finger, Hose and Tip w/ SC-6+*	0538011
RX-80 Repair Kit	0538215

*Includes additional a 3' whip hose and a 2-finger trigger.



▶ M-4 Mastic Gun



Panther ▶
P200Z

Panther P200Z

- ▶ Acetal tipped fluid nozzle prevents plating
- ▶ PTFE packing increases spraying time between maintenance
- ▶ The PTFE anodized body and air cap extends the life of the gun

DESCRIPTION	PART NO.
Panther Zinc Rich Gun	P200Z
Panther 200Z Repair Kit	10-108

REVERSIBLE TIP

- ▶ The best overall performing tip in the industry
- ▶ Fan pattern stays wider longer
- ▶ An orifice that outlasts competitive tips delivering consistent film thickness and less wasted paint
- ▶ Fits all Titan and most other industry spray gun guards



High Pressure Tip

High Pressure Tips 696-XXX

		ORIFICE SIZE (INCHES)														
	INCHES	MM	0.011	0.013	0.015	0.017	0.019	0.021	0.023	0.025	0.027	0.031	0.035	0.037	0.039	0.043
FAN PATTERN WIDTH	2-4	51-102														
	4-6	102-152	211	213												
	6-8	152-203			315	317	319	321	323	325						
	8-10	203-254			415	417	419									
	10-12	254-305			515	517	519	521	523	525	527	531	535	537		543
	12-14	305-356									627					
	14-16	356-406						721								
	16-18	406-457											835		839	
	18-20	457-508								923						
	Flow (gpm)	---	---	0.13	0.18	0.24	0.31	0.39	0.47	0.57	0.67	0.78	1.03	1.32	1.40	1.64
Flow (lpm)	---	---	0.45	0.68	0.91	1.17	1.47	1.78	2.15	2.53	2.95	3.89	4.99	5.29	6.20	7.52

Maximum Working Pressure: 7700 psi (53.1 MPa)

SC-6+ REVERSIBLE TIP

- ▶ The industry's longest-lasting orifice
- ▶ Up to 22% wider fan pattern
- ▶ Fits all Titan and most industry standard guards



SC-6+ Tips 662-XXX

		ORIFICE WIDTH (INCHES)															
	INCHES	MM	0.007	0.009	0.011	0.013	0.015	0.017	0.019	0.021	0.023	0.025	0.027	0.029	0.031	0.035	
FAN PATTERN WIDTH	4-6	102-152	207	209	211	213	215	217	219								
	6-8	152-203			309	311	313	315	317	319	321		325				
	8-10	203-254			409	411	413	415	417	419	421						
	10-12	254-305					511	513	515	517	519	521	523	525		531	535
	12-14	305-356			609	611	613	615	617	619	621	623	625	627	629	631	635
	Flow (gpm)	---	---	0.05	0.09	0.13	0.18	0.24	0.31	0.39	0.47	0.57	0.67	0.78	0.91	1.03	1.32
Flow (lpm)	---	---	0.19	0.34	0.45	0.68	0.91	1.17	1.47	1.78	2.15	2.53	2.95	3.44	3.89	4.99	

Maximum Working Pressure: 5000 psi (34.5 MPa)

Airless Spray Tip Guards

High Pressure Tip Guard (7/8") 661-027

- ▶ Interchangeable with most industry spray guns
- ▶ Pressure rated at 7700 psi (53 MPa)

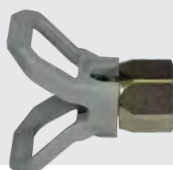

No Build Tip Guard (7/8") 0289228

- ▶ Interchangeable with most industry spray guns
- ▶ Pressure rated at 5000 psi (34.5 MPa)



Couplings

HOSE TO HOSE		
DESCRIPTION	BULK PART NO.	PACKAGED PART NO.
1/4" NPT(M) x 1/4" NPT(M)	5045	550063
1/4" NPT(M) x 3/8" NPT(M)	812-003	550064
3/8" NPT(M) x 3/8" NPT(M)	490-014	550066
1/2" NPT(M) x 1/2" NPS(M)	449-621	----

Maximum Working Pressure: 5000 psi (34.5 MPa)

HIGH PRESSURE HOSE TO HOSE	
DESCRIPTION	PART NO.
1/4" x 1/4" NPSM	367560
1/4" x 3/8" NPSM	367561
3/8" NPTF (M) x 3/8" NPTF(M)	9885643
3/8" NPTF (M) x 1/4" NPTF(M)	9885646
1/2" NPTF (M) x 1/4" NPTF(M)	9885644
1/2" NPTF (M) x 3/8" NPTF(M)	9885647
1/2" NPTF (M) x 1/2" NPTF(M)	9885648
3/4" NPSM x 3/8" NPSM	9985783
3/4" x 1/2" NPSM	9985782
3/4" x 3/4" NPSM	9985781
3/4" x 3/8" NPSM	9985783

Maximum Working Pressure: 7500 psi (51.7 MPa)

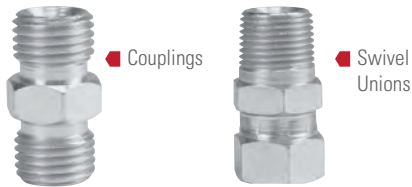

Swivel Unions

DESCRIPTION	PART NO.
1/4" NPS(F) x 1/4" NPT(M)	490-005
3/8" NPS(F) x 1/4" NPT(M)	490-042
1/4" NPS(F) x 3/8" NPT(M)	490-032
3/8" NPS(F) x 3/8" NPT(M)	490-043
1/2" NPS(F) x 1/2" NPT(M)	200-555
3/4" NPS(F) x 3/4" NPT(M)	138-037
1" NPS(F) x 1" NPT(M)	200-556

Maximum Working Pressure: 5000 psi (34.5 MPa)

Swivel Fittings

DESCRIPTION	PART NO.
1/4" NPS(F) x 1/4" NPS(F)	500-428
1/4" NPS(M) x 1/4" NPS(M)	500-424

Maximum Working Pressure: 5000 psi (34.5 MPa)

Liquids

MESH	PART NO.
AirCare™ 1 Qt. Bottle	311-101
Piston Lube™ 1 Qt. Bottle	700-926
Liquid Shield™ Plus 1 Qt. Bottle	314-482
Part Renu™ Starter Kit	0521010
Part Renu 1 Gallon Refill Bottle	0521423

Gun and Pump Filters

Titan's unthreaded filters are designed for quick and easy replacement.

For use with RX-Apex, RX-Pro, RX-80, G-10, LX-30, LX-40, LX-50, LX-70, S-3 and S-7.

UNTHREADED		
FILTERS	BULK PART NO.	2-PACK PART NO.
Coarse (Green)*	581-059	0089957
Medium (White)	581-060	0089958
Fine (Yellow)	581-062	0089959
Extra Fine (Red)	581-061	0089960

*Manifold filter for Advantage 400.

Pump Manifold Filters

For use on all PowrBeast, PowrCoat 7", 9" and 10" models.

MESH	PART NO.
10" Filter Support	0533515
Coarse-5 Mesh	920-001
Medium-50 Mesh*	920-004
Fine-100 Mesh	920-005
60 Mesh (PowrCoat 10")	0533514

*Standard with sprayer, excludes ball. Ball check sold separately (920-103).



Alloy Steel Gun Extensions

High Pressure, Alloy Steel Gun Extensions

When you need something a little more heavy duty. Can be used with most brands of airless spray guns.

- Pressure rated at 7700 psi (53.1 MPa).
- Fully packaged.

7/8" x 14 Thread is Standard

DESCRIPTION	PART NO.
10" (25 cm)	2442148
20" (50 cm)	2442149
30" (75 cm)	2442150

High Pressure Ball Valve

FITTING SIZE	psi	MPa	PART NO.
1/4"	6000	41.4	0533358
1/4"	7500	51.7	0533348
3/8"	6000	41.4	0533359
3/8"	7500	51.7	0533347

THE RIGHT EQUIPMENT FOR THE JOB



High Quality Airless Fluid Hoses and Whip Hoses

I.D.	LENGTH		MAX. WORKING PRESSURE - psi (MPa)					END CONNECTION
			3300 (22.8)	3600 (24.8)	4500 (31.0)	6500 (44.8)	7500 (51.7)	
	FEET	METERS	PART NO.	PART NO.	PART NO.	PART NO.	PART NO.	
1/8"	3	0.9	---	---	290685	---	---	1/4" NPSM (F/M)
	3	0.9	291004	---	---	---	---	1/4" NPSM (F/M)
3/16"	5	1.5	316-506	---	---	---	---	1/4" NPSM (F/M)
	9	2.7	550-222	---	---	---	---	1/4" NPSM (F/M)
	25	7.6	291007	---	---	---	---	1/4" NPSM (FBE)
	50	15.2	291008	---	---	---	---	1/4" NPSM (FBE)
1/4"	3	0.9	---	---	2389428	2389440	2389450	1/4" NPSM (FBE)
	6	1.8	316-533*	---	2389430	2389442	2389452	1/4" NPSM (FBE)
	6	1.8	550-227	---	---	---	---	1/4" NPSM (F/M)
	25	7.6	316-513	---	---	---	---	1/4" NPSM (FBE)
	50	15.2	316-505	286498	2389429	2389441	2389451	1/4" NPSM (FBE)
	100	30.5	---	---	2389427	2389439	2389449	1/4" NPSM (FBE)
3/8"	6	1.8	---	---	2389436	2389446	2389456	3/8" NPSM (FBE)
	25	7.6	508342	---	---	---	---	3/8" NPSM (FBE)
	50	15.2	291006	286499	2389434	2389445	2389455	3/8" NPSM (FBE)
	100	30.5	---	---	2389432	2389444	2389453	3/8" NPSM (FBE)
1/2"	25	7.6	225-112*	---	---	---	---	1/2" NPSM (FBE)
	50	15.2	250-112*	---	2389425	2389438	2389448	1/2" NPSM (FBE)
	100	30.5	---	---	2389424	2389437	2389447	1/2" NPSM (FBE)
3/4"	50	15.2	---	---	---	2389443	---	3/4" NPSM (FBE)

*Textile Braid. Spring guards at both ends.

FBE Female Both Ends, NPT National Pipe Tapered Thread, NPSM National Pipe Straight Mechanical Thread, MBE Male Both Ends, F/M 1 Female / 1 Male Connection

Moisture Resistant Hose

DESCRIPTION	PART NO.
3/8" x 50' 7500 psi Moisture Resistant Hose	375750050ML
3/8" x 50' 7500 psi Moisture Resistant Hose	375750050ML
1/2" x 50' 7500 psi Moisture Resistant Hose	500750050ML
3/4" x 12' 1000 psi Transfer Hose	750100012R



Air and Fluid Hose

DESCRIPTION	PART NO.
25' x 3/8" Fluid Hose	0277348
25' x 3/8" Air Hose	0550893

SPECIFICATIONS

Gas and Convertible



	PowrTwin 12000 Plus	PowrTwin 12000 Plus DI	Hydra X 4540	Hydra X 7230
Part Number - Gas	290016	290023	2412275 (Bare)	2412277 (Bare)
Max Delivery (gpm) - Gas	3.15 (11.9 lpm)	3.15 (11.9 lpm)	4.00 (15.1 lpm)	3.00 (1.4 lpm)
Max Delivery (gpm) - Elec	1.25 (4.7 lpm)	1.25 (4.7 lpm)	----	----
Max Tip Size, 1-Gun - Gas	0.058"	0.058"	0.067"	0.057"
Max Tip Size, 2-Guns - Gas	0.040"	0.040"	0.043"	0.035"
Max Tip Size, 3-Guns - Gas	0.034"	0.034"	0.035"	0.031"
Max Tip Size, 4-Guns - Gas	0.030"	0.030"	0.031"	0.027"
Max Tip Size, 5-Guns - Gas	0.026"	0.026"	0.025"	0.021"
Max Tip Size, 6-Guns - Gas	0.024"	0.024"	0.021"	----
Max Tip Size, 1-Gun - Elec	0.036"	0.036"	----	----
Max Tip Size, 2-Guns - Elec	0.026"	0.026"	----	----
Max. Operating Pressure (psi)	3600 (26.4 MPa)	3600 (26.4 MPa)	4500 (31.0 MPa)	7200 (49.6 MPa)
Engine	270cc Honda® GX 270	270cc Honda® GX 270	390cc Honda® GX 390	390cc Honda® GX 390
Electric Motor	2.0 HP TEFC DC	2.0 HP TEFC DC	----	----
Max. Hose Length	400' (121.9 m)	400' (121.9 m)	----	----
Paint Outlet - Filter Element	50-Mesh	50-Mesh	----	----
Paint Outlet - Filter Area	18-inches ² (45.7 cm ²)	18-inches ² (45.7 cm ²)	----	----
Weight - Gas (lbs)	182 (82.6 kg)	188 (85.3 kg)	385 (175 kg)	385 (175 kg)
Weight - Electric (lbs)	188 (85.3 kg)	192 (87.1 kg)	----	----
Dimensions (H x W x L) - Unit	35" x 27" x 46" (89 x 68.5 x 117 cm)	35" x 27" x 46" (89 x 68.5 x 117 cm)	52" x 32" x 48" (132 x 81 x 121 cm)	52" x 32" x 48" (132 x 81 x 121 cm)
Gun Included	RX-Apex, Non-filtered	RX-Apex, Non-filtered	----	----
TR ¹ Tip Included	517	517	----	----
Airless Hose Included	1/4" x 50'	3/8" x 50'	----	----

Pneumatic



	PowrCoat 730	PowrCoat 745	PowrCoat 940	PowrCoat 960	PowrCoat 1045	PowrCoat 1064	PowrCoat 1072
Model Number	0533730C (Bare)	0533745C (Bare)	0533940C (Bare)	0533960C (Bare)	05331045C (Bare)	05331064C (Bare)	05331072C (Bare)
Pressure Ratio	30:1	45:1	40:1	60:1	45:1	64:1	72:1
Max. Operating Pressure	3000 psi (207 bar)	4500 psi (310 bar)	4000 psi (276 bar)	6000 psi (414 bar)	4500 psi (310 bar)	6400 psi (441 bar)	7250 psi (500 bar)
Max. Air Inlet Pressure	100 psi (6.9 bar)	100 psi (6.9 bar)	100 psi (6.9 bar)	100 psi (6.9 bar)	100 psi (6.9 bar)	100 psi (6.9 bar)	100 psi (6.9 bar)
Cycle Rate (Per Gallon/Liter)	21.2 / 5.6	31.1 / 8.2	21.2 / 5.6	31.1 / 8.2	15 / 3.9	20 / 5.3	22.5 / 5.9
Volume (Per Double Stroke)	178.3 cc	121.6 cc	178.3 cc	121.6 cc	253.8 cc	188.5 cc	167.1 cc
Maximum Volume Flow @ Cycles Per Minute (CPM)							
60 CPM	3.0 gal (10.7 l)/min	2.0 gal (7.3 l)/min	3.0 gal (10.7 l)/min	2.0 gal (7.3 l)/min	4.0 gal (15.2 l)/min	3.0 gal (11.3 l)/min	3.0 gal (10.0 l)/min
Fluid and Air Specifications							
Inlet	1" NPT(F)	1" NPT(F)	1" NPT(F)	1" NPT(F)	3/4" NPT(F)	3/4" NPT(F)	3/4" NPT(F)
Outlet	1/2" NPT(F)	1/2" NPT(F)	1/2" NPT(F)	1/2" NPT(F)	3/4" NPT(F)	3/4" NPT(F)	3/4" NPT(F)
Hose Connection	3/8" NPSM(M)	3/8" NPSM(M)	3/8" NPSM(M)	3/8" NPSM(M)	3/8" NPSM(M)	3/8" NPSM(M)	3/8" NPSM(M)
Approximate Air Requirement Per Gallon of Output @ 100 psi (6.9 bar) Air Pressure	28 SCFM (0.79m ³ /min)	40 SCFM (1.13m ³ /min)	36.4 SCFM (1.03m ³ /min)	53 SCFM (1.50m ³ /min)	43 SCFM (1.22m ³ /min)	57.7 SCFM (1.63m ³ /min)	64.9 SCFM (1.84m ³ /min)
Air Inlet	3/4" NPT(M)	3/4" NPT(M)	3/4" NPT(M)	3/4" NPT(M)	3/4" NPT(M)	3/4" NPT(M)	3/4" NPT(M)
Max. Sound Pressure Level	106 dB*	106 dB*	106 dB*	102 dB*	98 dB*	98 dB*	98 dB*
Max. Temperature	140° F (60° C)	140° F (60° C)	140° F (60° C)	140° F (60° C)	160° F (71° C)	160° F (71° C)	160° F (71° C)
Filter Insert (Standard)	50-Mesh (18 in ²)	50 mesh (18 in ²)	50-Mesh (18 in ²)	50-Mesh (18 in ²)	60-Mesh, 97 cm ² (15 in ²)	60-Mesh, 97 cm ² (15 in ²)	60-Mesh, 97 cm ² (15 in ²)
Weight	132 lbs (59.9 kg)	133 lbs (60.3 kg)	140 lbs (63.5 kg)	139 lbs (63 kg)	195 lbs (88.4 kg)	195 lbs (88.4 kg)	195 lbs (88.4 kg)
Dimensions (L x W x D)	34.75 x 26.25 x 49" (88.3 x 66.7 x 124.5 cm)	34.75 x 26.25 x 49" (88.3 x 66.7 x 124.5 cm)	34.75 x 26.25 x 49" (88.3 x 66.7 x 124.5 cm)	34.75 x 26.25 x 49" (88.3 x 66.7 x 124.5 cm)	33.5 x 31.35 x 539.9" (85.09 x 79.63 x 136.90 cm)	33.5 x 31.35 x 539.9" (85.09 x 79.63 x 136.90 cm)	33.5 x 31.35 x 539.9" (85.09 x 79.63 x 136.90 cm)
Repair Parts							
55-Gallon Siphon Set	103-826	103-826	103-826	103-826	533259	0533259	533259
Packing Kit	185-050	155-050	185-050	155-050	533936	533937	533938
Piston Rod	185-984A	155-982	185-984A	155-982	533677	533689	533939
Cylinder	183-930	155-932	183-930	155-932	533676	533688	533699



WEARGUARD CONVENIENCE PROGRAM KEEPS YOU UP AND RUNNING

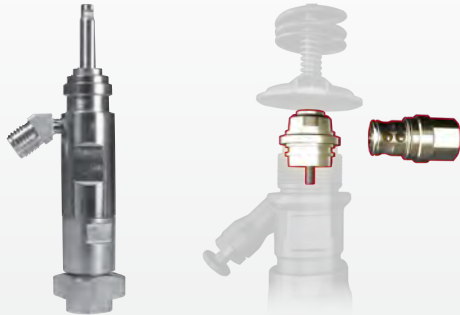

When you purchase a new Titan sprayer, you're able to take advantage of our exclusive WearGuard Convenience Program. Protect your investment by purchasing a spare fluid section or PermaStroke kit at a discounted rate. Save yourself the time and frustration of an extra trip or waiting for parts to arrive in the event that your sprayer goes down. When you have a backup fluid section or PermaStroke kit on hand, replacement can quickly be made without leaving the jobsite and doesn't require special tools. The bottom line is that WearGuard keeps you up and running.

Not interested in purchasing a spare fluid section? We also offer the option of a free packing kit on select sprayers.

For more information on pricing and how to order, go to:

www.titanwearguard.com or scan the QR code.



KEEP TITAN WITH YOU WHEREVER YOU GO

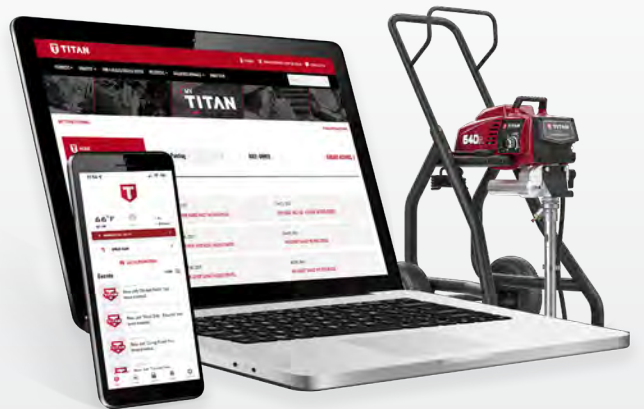

MyTitan™ gives you immediate access to all things Titan. Anywhere, anytime on your computer or mobile device. MyTitan gives you everything you need to get the most out of your sprayers, all in one place, no matter where the workday takes you. MyTitan is designed to make your life easier, your business more efficient, and your day more productive—so you can stay ahead of the game, do more in less time, and never lose track of another detail.

For more information on this new app, go to:

www.titantool.com/mytitan-welcome or scan the QR code.



THOR
TITAN HUB FOR ONLINE REDEMPTION

ONLINE REWARD REDEMPTION NO CLIPPING. NO STAMPS. NO HASSLES.

For more information and to see current promotions, go to:
www.titantool.com/thor-promos or scan the QR code.



All information contained in this brochure is based on the latest information available at the time of printing. Titan reserves the right to make changes at any time, without notice. Due to continuous innovation, specifications may progressively change. Contact one of our dependable sales reps or call our dedicated customer service team for more information.